

EBCHQ

71530 /HVL 031 Heater



- Compact / Flat design
- High air through-flow
- Temperature safety cut-out
- Clip fixing

Compact high-performance fan heater prevents formation of condensation and frost and provides an evenly distributed interior air temperature in enclosures with electric/electronic components.

Size chart

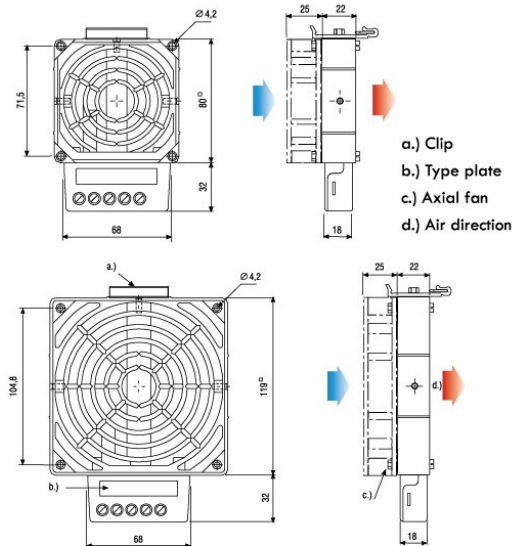

71530	Heater with fan
Heating element	high performance cartridge
Temperature safety cut-out	to protect against overheating in case of fan failure
Heater body	die-cast aluminium(glass bead blasted)
Connection	3-pole screw connector 2.5mm ² ,clamping toeque 0.8Nm max
Connection casing	plastic according to UL94 V-0,BLACK
Mounting	clip for 35mm DIN rail,EN50022
Fitting position	horizontal
Operating/Storage temperature	-45 to +70°C/(-49 to +158°F)
Protection type/Protection class	IP20/1(earthed)
Service life	service life 50,000h at 25°C/(77°F)
Connection(axial fan)	2-pole screw connector 2.5mm ² (L2/N2)

Art.no.HVL 031	Heating capacity	Airflow min	Dimensions	Weight(approx.)
120 vac,50/60Hz		free flow		
03103.9-00	150W	35m ³ /h	80x112x47mm	0.60kg



Important! Heater may only be operated together with fan. Danger of overheating!